

KG(X)10



10HP High Flow Grinder Pump (Class 1, Div. 1, Groups C & D Hazardous Location)



The KEEN PUMP **KG(X)10** series centrifugal grinder pumps easily handle residential, commercial or industrial sanitary waste, reducing it to a fine slurry. The **KG(X)10** pump is designed for use in pressure sewer applications or any piping network.

The recessed vortex impeller design of the **KG(X)10** grinder pump provides trouble-free, non-overloading operation over the entire performance curve. The modular design provides quick and easy serviceability. The hardened stainless steel grinder assembly provides many years of dependable operation.

The **KG(X)10** series pump features:

- Interchangeable with Competitor Installations
- Dual Silicon-Carbide Mechanical Shaft Seals w/ Viton[®] Elastomers
- Pressed-In Motor with Internal Overload Protection
- 3-Bearing Shaft Support (Upper / Lower / Sleeve)
- Internal Moisture Detection
- Strong Motor 230/460 volt, 3-Phase

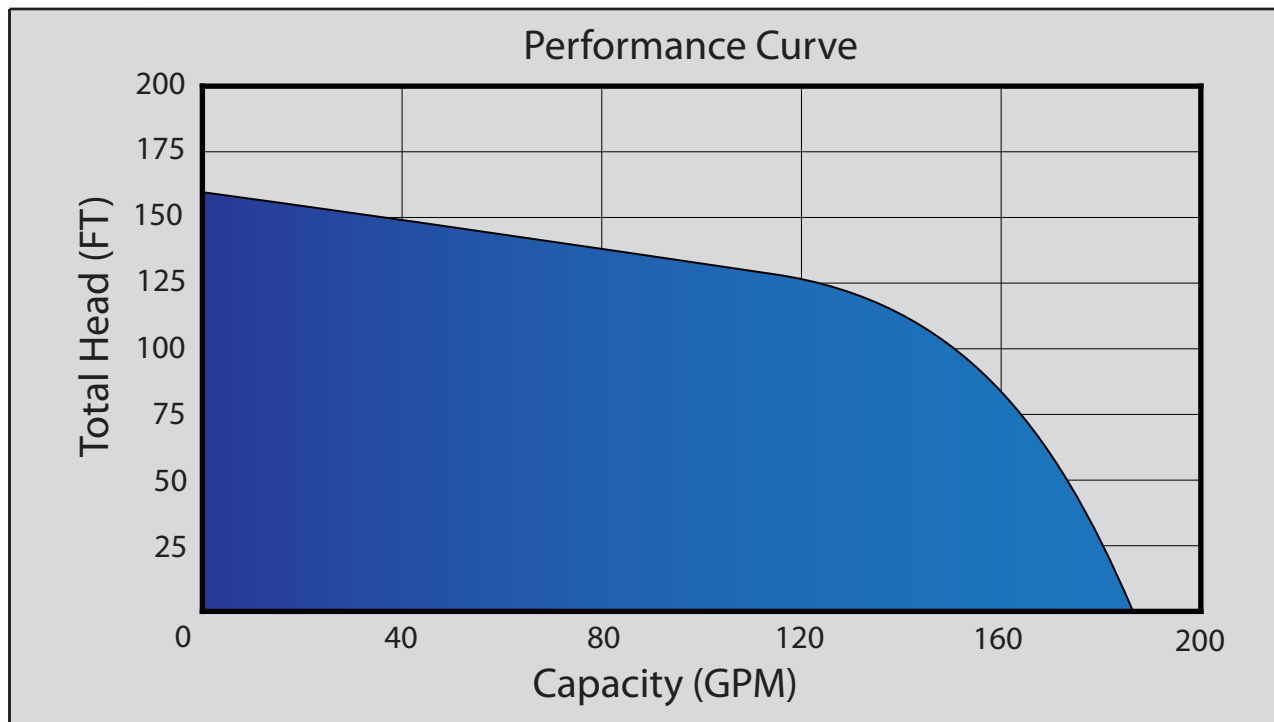

Features and Benefits

1. Watertight Cable Entrance

Agency-approved, watertight strain relief cord grip with compression grommet protects outer cord jacket (**FM Explosion-Proof**) or Heavy-duty molded compression grommet protects outer cord jacket. Epoxy-filled inner cord cap provides anti-wicking moisture protection to the motor even if power cable is cut or damaged.

2. Modular Pump Design

Commonality of parts across the Keen product line minimizes the amount of parts required for servicing. Heavy-duty ASTM A48, Class 35 cast iron components.

3. Strong Motor

Powerful high-torque motor for reliable pump operation. Pressed stator securely holds motor and efficiently transfers heat. Class F insulation with overload protection in oil-filled chamber for cool operation and long motor life.

4. 3-Bearing Support

Motor / Pump shaft securely held with upper and lower ball bearing plus additional sleeve bearing in lower seal chamber. Long 100,000 hour L-10 bearing life.

5. Double Mechanical Seal Protection

Dual silicon carbide mechanical shaft seals w/ Viton® Elastomers provide twice the moisture protection for the motor. Dual seals are housed in a secondary oil-filled seal chamber. Tougher silicon carbide seals better handle sand, grit and abrasive materials.

6. Moisture Detection

Dual Seal leak probe signals alarm in control panel for scheduled maintenance.

7. Non-Overloading Hydraulic Design

The recessed centrifugal impeller allows 100% performance curve operation from shut-off to maximum flow without damage to the pump or system. The recessed vortex impeller is out of the passageway of fluid flow, eliminating concerns of blockage or wear.

8. Proven Grinder Assembly

Hardened (Rockwell 56-60) stainless steel grinder assembly has 30+ years proven field experience. The reversible grinder ring and grinder impeller effectively reduce solids into a fine slurry, easily passable in a piping system without concerns of clogging. Highly efficient 17,250 cuts/second.

9. Versatile Flange Connection

Combination 2-1/2" and 3" horizontal flange. Industry-standard ANSI Class 125 dimensions.

10. Accessories

Stainless steel lifting handle included. Anti-vibration nylon mounting feet **OPTIONAL**.

10HP Grinder Pump High Flow KG(X)10

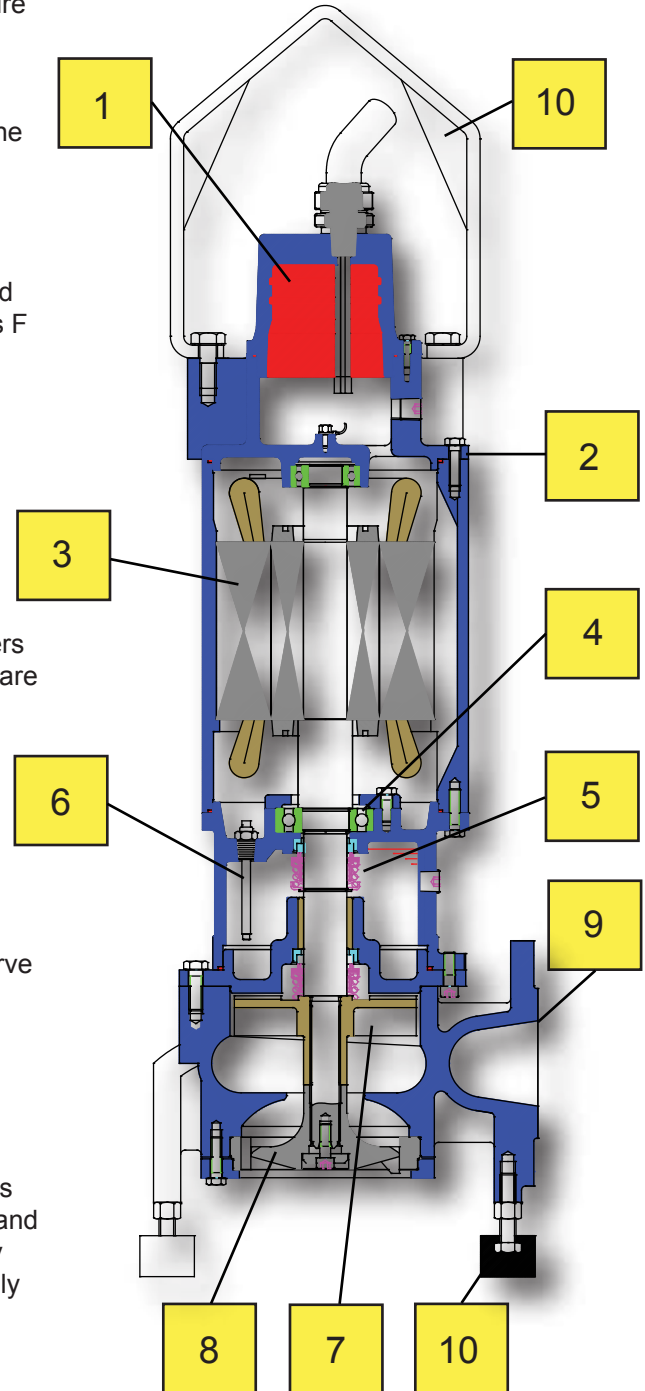

471 US HWY 250 East · Ashland, Ohio 44805
419.207.9400 fax 419.207.8031
www.keenpump.com



10HP SUBMERSIBLE GRINDER PUMP

GENERAL		MOTOR DATA	
Pump Model	KG(X)10	HP / Power Supply	10HP / 3 ϕ , 60 Hz
PUMP DATA		Full Load Amps 230V	40 Amps
Date	07/08/2015	Start Amps 230V	135 Amps
Discharge Flange	2-1/2 & 3" ANSI Horizontal	Full Load Amps 460V	20 Amps
Grinder Ring	25 Slots	Start Amps 460V	75 Amps
Impeller Type / Std. Dia.	Recessed / 6.75"	Poles / Rated Speed	2 P / 3450 rpm
Three Phase		Insulation Class	F Class

PERFORMANCE CURVE

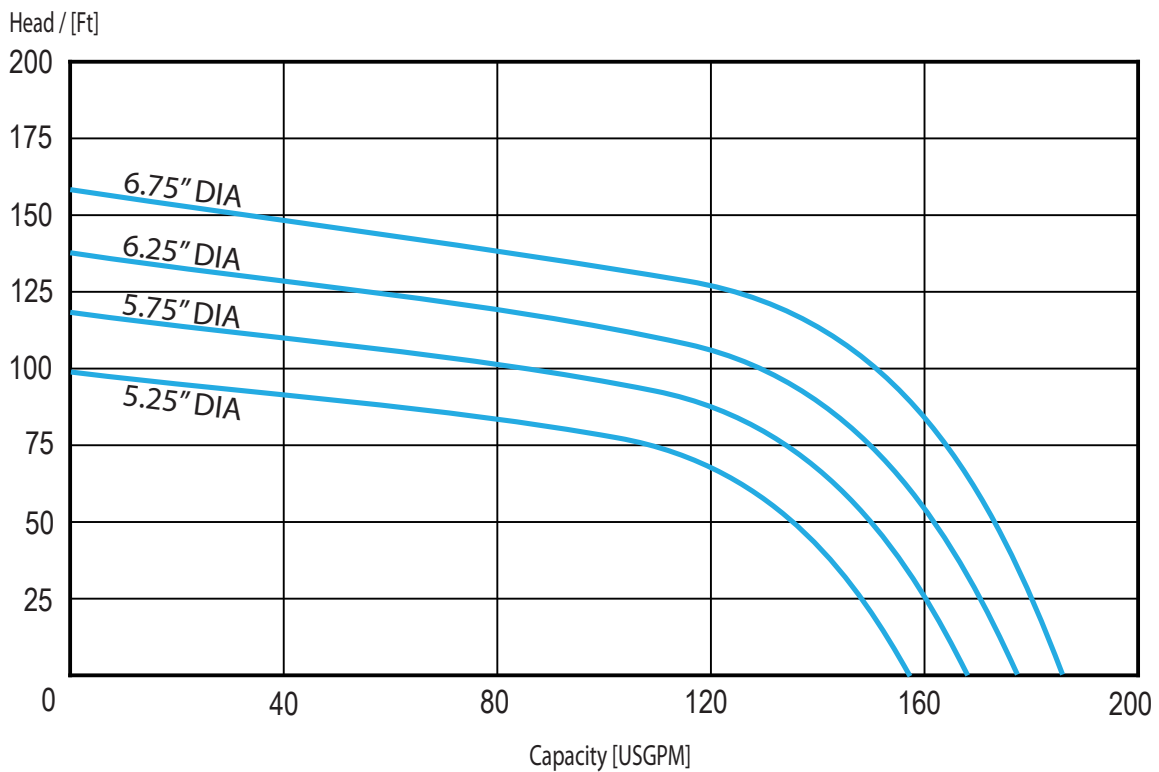

<u>MODEL</u>	<u>HP</u>	<u>Phase</u>	<u>Volts</u>
KG(X)10-2303	10	3	230
KG(X)10-4603	10	3	460

* Performance with clear water and ambient temp 20°C (68°F)

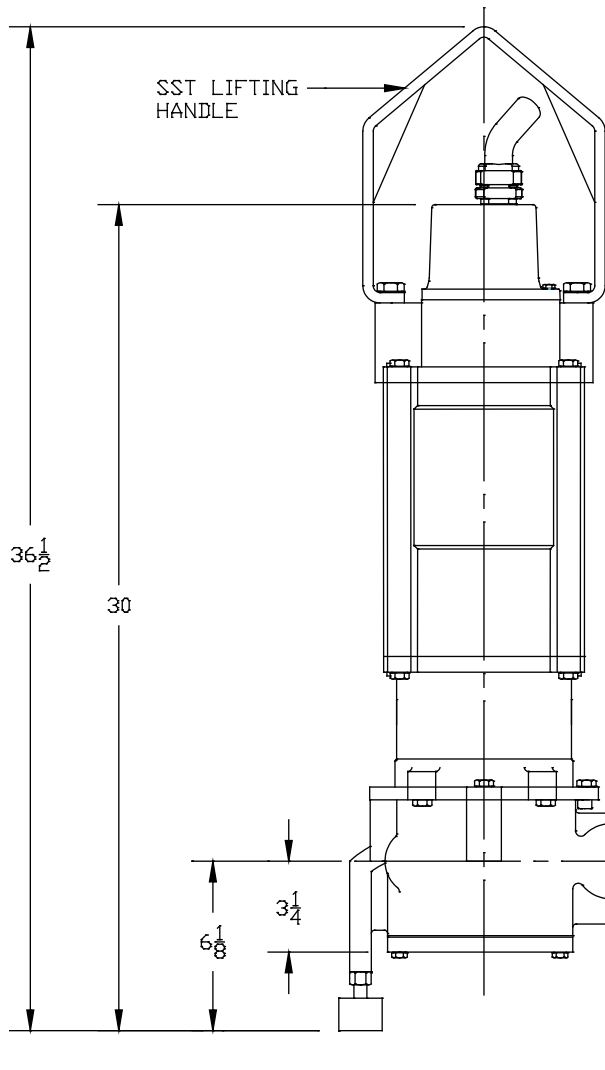
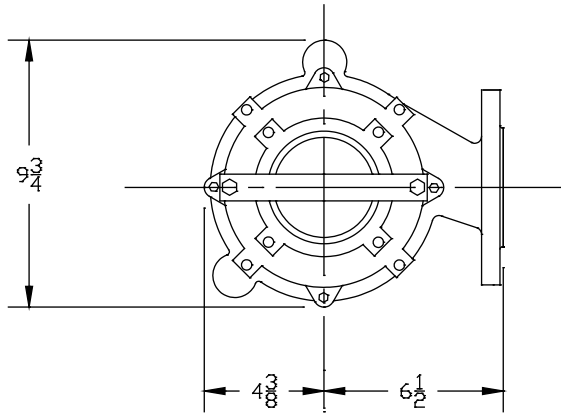

SST LIFTING HANDLE

* PUMP STANDARD HORIZONTAL FLANGE
(2-1/2" OR 3" ANSI) STANDARD BASIN
PACKAGE DISCHARGE (2" PIPING)
ACCEPTABLE WITH MACERATED
SEWAGE SLURRY

* DISCHARGE FLANGE "SLOTS"
FOR OPTIONAL 2.5" OR 3" ANSI
DISCHARGE, CLASS 125, 4-BOLT

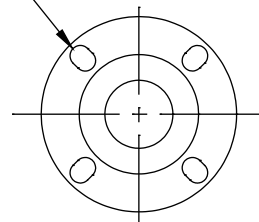

NOTE: ALL DIMENSIONS FOR REFERENCE ONLY

D	SE	01/06/2017
REV	INITIALS	DATE

		KEEN PUMP CO. 471 US HWY 250 EAST ASHLAND, OHIO 44805	PHONE: 419-207-9400 FAX: 419-207-8031
TITLE KG10 10HP HIGH FLOW GRINDER PUMP DIMENSIONS			
SCALE NTS		DWG. # KN-670	REV. D
DWG. BY SE	DATE 01/03/2013		